

A B C D E F

REV.	MODIFICATION.	DATE	DRN
01	ECN2007-241	18/12/07	SF
02	CO2010167	28/03/08	SF
03	CO2011001	11/10/10	SF
04	CO2011253	12/04/12	SF

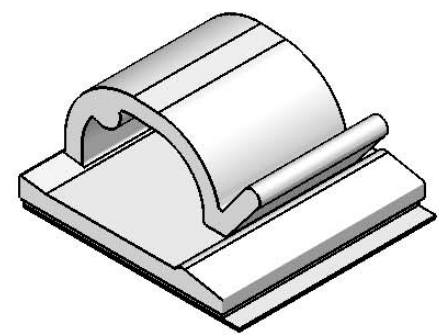
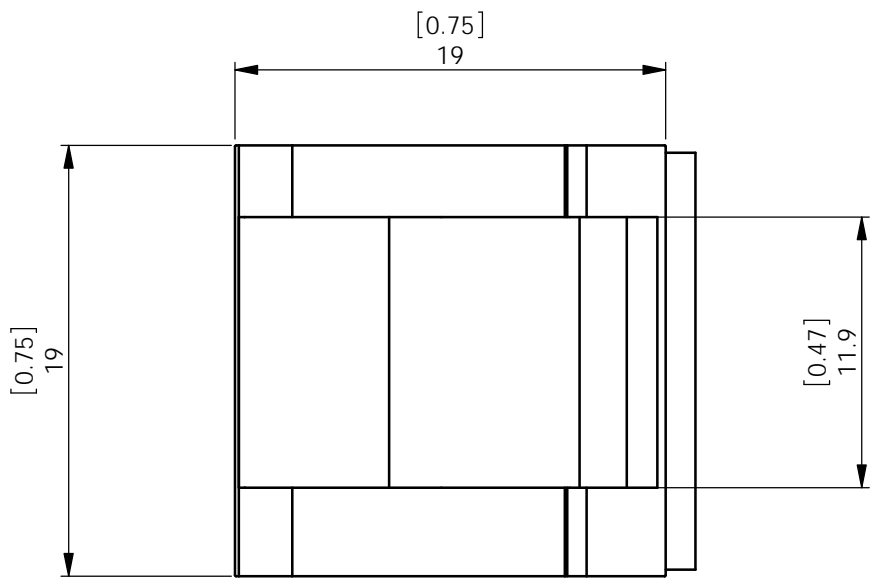

NOTES:

1. MATERIAL: NYLON 6/6 UL94-V2(RMS-01)
2. TAPE:ADHESIVE (RMS-024)
3. PARTS AVAILABLE IN NYLON 6/6 UL94-V0(RMS-19) BY SPECIAL ORDER
4. PARTS ALSO AVAILABLE IN BLACK BY SPECIAL ORDER, ADD BK TO END OF PART NUMBER.

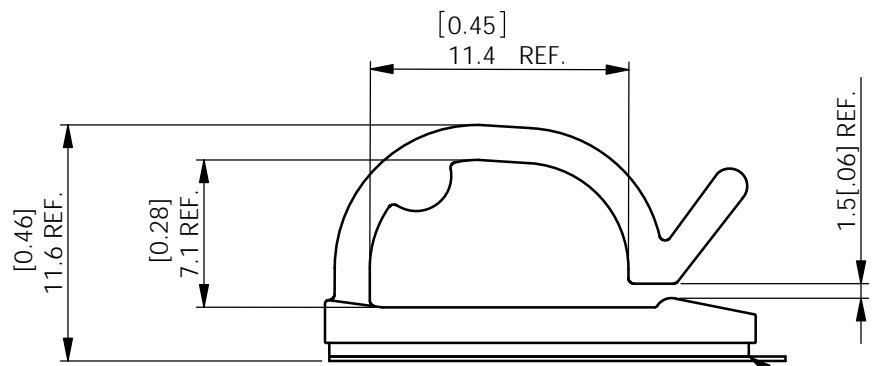

0.8 [1/32] THICK, DOUBLE SIDED ADHESIVE TAPE WITH RELEASE TAB.

INFORMATION CONTAINED IN THIS DOCUMENT IS CONFIDENTIAL TO RICHCO INTERNATIONAL Co. Ltd. AND MAY NOT BE DISCLOSED OR REPRODUCED IN WHOLE OR PART WITHOUT THEIR WRITTEN CONSENT.

RICHCO, INC. WWW.RICHCO-INC.COM	ALL DIMENSIONS IN mm GENERAL TOLERANCES ±0.25 UNLESS OTHERWISE STATED 1 DECIMAL PLACE ±0.25 2 DECIMAL PLACES ± 0.10 ANGULAR ±1°	THIRD ANGLE

PART NUMBER
MWCK-460-01A4
MWCK-460-01
MWCK-460-19

MATERIAL: SEE NOTES		COLOUR: NATURAL	
DESCRIPTION: WIRE CORD KLIP		PART No: SEE TABLE	
DRG No: 07-146	NPR No: N/A	Mass:(g) 0.9	SHEET SIZE A4
DRN SF	DATE 18/12/07	CHKD TC	DATE 18/12/07
SCALE NTS		SHEET No. 1 OF 1	

A B C D E F