

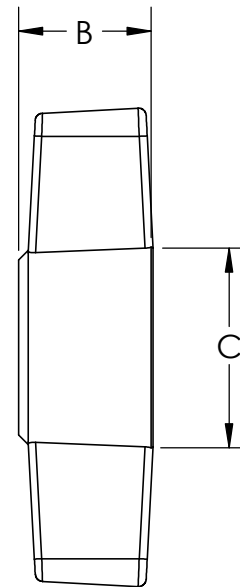

SIZE	A	B	C
KSN8----T2--5--	1.250	0.340	0.530
KSN1----T2--5--	1.250	0.340	0.530
KS4X----T2--5--	1.250	0.340	0.530
KSM4----T2--5--	1.250	0.340	0.530
KSM5----T2--5--	1.250	0.340	0.530

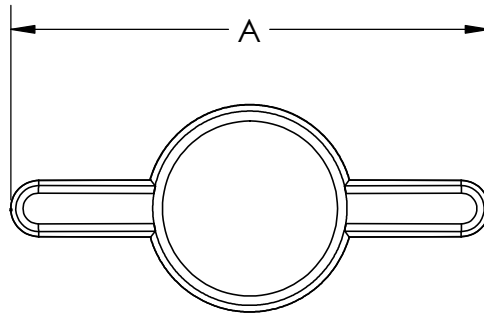

FOR CUSTOMER APPROVAL ONLY				REV	BY	DATE	COMMENT	DIMENSIONS ARE IN INCHES TOLERANCES FRACTIONAL ± TWO PLACE DECIMAL ± 0.03 THREE PLACE DECIMAL ± 0.010 UNLESS OTHERWISE NOTED	DRAWN	VRR	 INNOVATIVE COMPONENTS PART NAME 1.25" T-Knob Accepts Socket Head Cap Screw, Acetal, Black	
NAME:	0	CG	02/25/20	RELEASE DATE					APPROVED	LQR		
TITLE:									DATE	02/26/2020		
DATE:									COMMENTS			
SIGNATURE:									KNOB MATERIAL Acetal, Black			
PROPRIETARY AND CONFIDENTIAL								KNOB FINISH Textured			PART NUMBER GANG PRINT KS-T2-BLACK	DRAWING NUMBER GANG PRINT KS-T2-BLACK-R0
											SCALE 2:1	SHEET 1 OF 1

