

MATERIAL: NYLON 6/6 UL 94 V-2 (RMS-01) COLOR: NATURAL PART NO.	MATERIAL: NYLON 6/6 UL 94 V-0 (RMS-19) COLOR: NATURAL PART NO.	DIM. "A" ±.015 [0.4]
PS-3-01	PS-3-19	3/16 [4.8]
PS-4-01	PS-4-19	1/4 [6.4]
PS-6-01	PS-6-19	3/8 [9.5]
PS-7-01	PS-7-19	7/16 [11.1]
PS-8-01	PS-8-19	1/2 [12.7]
PS-9-01	PS-9-19	9/16 [14.3]
PS-10-01	PS-10-19	5/8 [15.9]
PS-12-01	PS-12-19	3/4 [19.1]
PS-14-01	PS-14-19	7/8 [22.2]

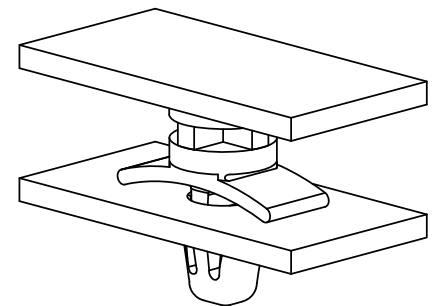

TYPICAL APPLICATION

NOTES:

1. MATERIAL: "IMPACT MODIFIED" NYLON 6/6 (RMS-73)
AVAILABLE BY SPECIAL ORDER ONLY.
TO ORDER RELACE "-01" WITH "-73".
MATERIAL: " HEAT RESISTANT" NYLON 4/6 UL 94 V-2 (RMS-109)
AVAILABLE BY SPECIAL ORDER ONLY.
TO ORDER REPLACE "-01" WITH "-109"
2. COLOR: BLACK AVAILABLE BY SPECIAL ORDER ONLY.
TO ORDER ADD SUFFIX "BK" TO PART NO.
3. PART IS ALSO AVAILABLE IN A 1/8 (3.2) THICK CHASSIS BY
SPECIAL ORDER ONLY. TO ORDER USE P/N: PS-2-XX-XX

REV.			TITLE: PUSH SPACER			UNITS: IN [mm]		FINAL	
I	ADDED PS-9, ECN # 1368	DZ 07/03/2012	CREATED USING SOLIDWORKS	FILE #: PS	DWN: SK	APP: SK	PART #		PRINT TYPE
H	SEE ECN #1208 FOR CHANGES	SK 11/29/2006	TOLERANCES UNLESS NOTED	SHEET: 1 OF 1	SHEET SIZE: A	DT: 02/24/05	CHKD: DZ	SEE TABLE	CA
G	SEE ECN #1196 FOR CHANGES	SK 07/17/2006	.XX=±.010	RE: RICHCO, INC.		RICHCO, INC. ENG@RICHCO-INC.COM (773) 539-4060			
F	COMPLETELY REDRAWN, SEE ECN #949	SK 02/24/2005	.XXX=±.005						
-	SEE ENGINEERING FOR REVISIONS A-E	-	FRAC.=±1/64						
	DESCRIPTION	ENGR. DATE	ANG.=±1°						