

UNCONTROLLED DOCUMENT

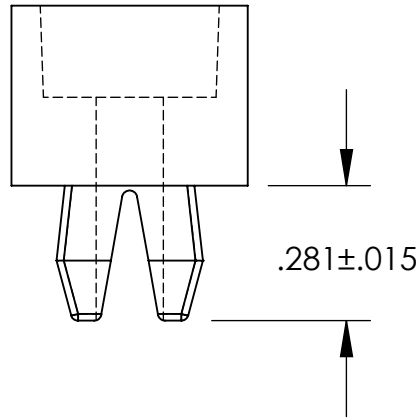
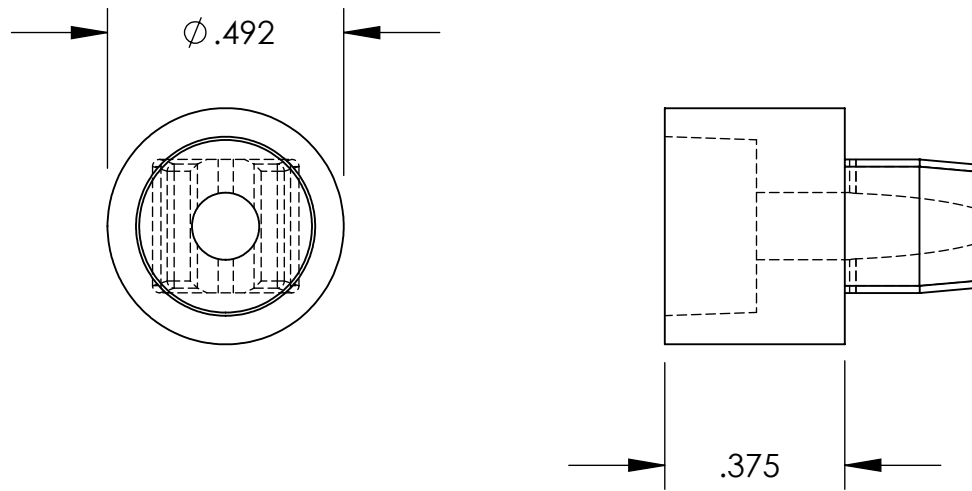

NOTES:
 HOLE SIZE .281 / .286
 PANEL THICKNESS RANGE .031 / .109
 SCREW SIZE #8-#10

WE RESERVE THE RIGHT
 TO DISCONTINUE ITEMS,
 CHANGE SPECIFICATIONS
 OR DESIGN AT ANY TIME
 WITHOUT NOTICE AND
 WITHOUT INCURRING
 ANY OBLIGATIONS

TOLERANCES UNLESS NOTED

- ±.005 ON DIMENSIONS THRU .625
- ±.008 ON DIMENSIONS .626 THRU 1.000
- ±.010 ON DIMENSIONS 1.001 THRU 1.500
- ±.015 ON DIMENSIONS LARGER THAN 1.500
- ±.015 ON FRACTIONAL DIMENSIONS

PROPERTY OF		
MICRO PLASTICS INC.		
CATALOG DRAWING ROUND HEAD GROMMET NUT MICRO P/N 60SGN00911 DWG. # 60SGN00911 FILE SERVER\ENG\WEB		
MATERIAL:		NYLON 6/6
DATE	SCALE	TA
	2.5:1	